

Phylogenetic and biogeographic study of the Andean genus *Grundulus* (Teleostei: Characiformes: Characidae)

CÉSAR ROMÁN-VALENCIA¹, JAMES A. VANEGAS-RÍOS & RAQUEL I. RUIZ-C.

¹ Universidad del Quindío, Laboratorio de Ictiología, A. A. 2639, Armenia, Quindío, Colombia
ceroman(at)uniquindio.edu.co, ceroman(at)uniquindio.edu.co, zutana_1(at)yahoo.com

Received on April 30, 2009, accepted on July 30, 2010.

Published online at www.vertebrate-zoology.de on September 02, 2010.

> Abstract

We analyzed a matrix of 55 characters to study the phylogenetic relationships and historical biogeography of the three species of the genus *Grundulus*. The most parsimonious hypothesis explaining phylogenetic relationships of *Grundulus* species is expressed in a tree with a length of 84 steps, (consistency index 0.80, retention index 0.88, rescaled consistency index 0.70). The monophyly of a clade containing the Cheirodontinae and *Grundulus* is supported by five synapomorphies; within this clade *Grundulus* is found to be the sister-group of *Spintherobolus*, as supported by nine synapomorphies. In the proposed hypothesis, the monophyly of *Grundulus* is supported by eleven synapomorphies and *G. quitoensis* is sister to a clade including *G. cochae* and *G. bogotensis*. The biogeographical analysis suggests that *Grundulus* is a genus endemic to coldwater lakes of glacial origin in the Andes of northern South America. The taxon-area cladogram shows a high congruence between the areas and phylogeny of the taxa, where each area harbors a particular species. The most closely related areas are La Cocha, a coldwater lake from the Amazon basin (A), and the Bogotá plateau from the Magdalena basin (B). The Pacific Andean region on Ecuador is the sister area of A and B.

> Resumen

Se estudiaron las relaciones filogenéticas y la biogeografía histórica entre las especies del género *Grundulus*, concentrándose en la filogenia de sus especies. Con este propósito se analiza una matriz de 55 caracteres. La hipótesis más parsimoniosa que explica las relaciones filogenéticas de las especies de *Grundulus* correspondió con el árbol con una longitud de 84, índice de consistencia 0,80, índice de retención 0,88 e índice de consistencia reescalado 0,70. Las relaciones entre peces cheirodontinos y *Grundulus* fueron soportadas por cinco sinapomorfías. Mientras que nueve sinapomorfías soportan una estrecha relación filogenética entre *Grundulus* y *Spintherobolus* (Cheirodontinae), además, la monofilia de *Grundulus* se apoya en once sinapomorfías. Una estrecha interrelación se evidencia entre *G. cochae* y *G. bogotensis*, taxones hermanos, más que con *G. quitoensis*. Así, *G. quitoensis* fue el grupo hermano de éstas especies. El análisis biogeográfico indica que *Grundulus* es endémico de la cordillera de los Andes al norte de América del Sur, en lagos de origen glacial. El cladograma taxonómico de áreas mostró una alta congruencia entre las áreas y la filogenia de los taxones, así cada área está ocupada por un taxón en particular. Las áreas más estrechamente relacionadas son la laguna de La Cocha en la cuenca del Amazonas (A) y La sabana de Bogotá en la cuenca de Magdalena (B). El Pacífico en Ecuador corresponde al área hermana de A y B.

> Key words

Systematics, vicariance, Colombia, Ecuador, South America, *Grundulus*, Cheirodontinae.

Introduction

The genus *Grundulus* VALENCIENNES in CUVIER and VALENCIENNES, 1846 has three valid species from Andean coldwater lakes of northern South America in the northwestern Andes: *G. bogotensis* HUMBOLDT in

HUMBOLDT & VALENCIENNES, 1833 from the Bogotá plateau (Magdalena basin of Colombia); *G. cochae* ROMÁN-VALENCIA, PAEPKE & PANTOJA, 2003 from La Cocha lake, located in southern Colombia (Amazon

basin); and *G. quitoensis* ROMÁN-VALENCIA, RUIZ-C. & BARRIGA, 2005 from El Voladero lakes in northern Ecuador (Pacific drainage).

Grundulus was traditionally included in the subfamily Cheirodontinae (EIGENMANN, 1915, 1922; DAHL, 1971; MILES, 1971; GÉRY, 1977); although MALABARBA (1998), WEITZMAN & MALABARBA (1999) and ROMÁN-VALENCIA *et al.* (2003) have shown that *Grundulus* does not have the diagnostic characters of Cheirodontinae. Moreover, WEITZMAN and MALABARBA (1999) failed to resolve the phylogenetic relationships between *Grundulus* with other characids (i.e. with *Spintherobolus* EIGENMANN, Cheirodontinae). Therefore, *Grundulus* was recognized as *incertae sedis* within Characidae (MALABARBA, 1998; WEITZMAN & MALABARBA, 1999; REIS *et al.*, 2003). ROMÁN-VALENCIA *et al.* (2005) proposed four diagnostic characters for *Grundulus*: adipose fin absent, reduced number of pored lateral-line scales, slender supraorbital and pelvic bones present; but we observed here that the supraorbital bone is absent in all species of *Grundulus*.

An assessment of the phylogenetic position of *Grundulus* within Characidae is beyond the scope of this paper. Here we reconstruct the phylogenetic relationships of *Grundulus* species and present additional evidence confirming its monophyly based on morphological features. We also present a hypothesis of historical biogeography using the proposed phylogeny as well current known geographic distributions of the species.

Methods and materials

Osteological preparation. Fish were cleared and double-stained with Alcian blue for cartilage and Alizarin red for bone using the method outlined by TAYLOR & VAN DYKE (1985).

Terminology. Osteological terminology is that used by WEITZMAN (1962) with the modifications proposed by VARI & HAROLD (2001), MURRAY (2004) and RUIZ-C. & ROMÁN-VALENCIA (2006). The classification of Characidae used in this paper follows MALABARBA & WEITZMAN (2003) and REIS *et al.* (2003). We followed MALABARBA (1998) and BÜHRNHEIM & MALABARBA (2007) in the systematics of the Cheirodontinae used herein.

Phylogenetic analysis. Because *Grundulus* does not have a previously defined sister group and it is currently considered as *incertae sedis* within Characidae (LIMA *et al.*, 2003), most analyzed outgroups are characid fishes included in some previous phylogenetic studies (LUCENA, 1993; WEITZMAN & MALABARBA, 1999;

MALABARBA & WEITZMAN, 2003; CALCAGNOTTO *et al.*, 2005; WEITZMAN *et al.*, 2005). Some of these genera (e. g. *Astyanax* BAIRD & GIRARD, *Alestes* MÜLLER & TROSCHER, *Brycon* MÜLLER & TROSCHER, see below) were hypothesized in the literature to be basal within Characidae (LUCENA, 1993; WEITZMAN & MALABARBA, 1999; MURRAY & STEWART, 2002; MALABARBA & WEITZMAN, 2003; CALCAGNOTTO *et al.*, 2005; WEITZMAN *et al.*, 2005). The chosen outgroups permit the polarization of characters during the analyses. The principal evidence for the monophyly of *Grundulus* was taken from ROMÁN-VALENCIA *et al.* (2003). Our intention is test the phylogenetic relationships among *Grundulus* species.

The ingroup is formed by the species of *Grundulus*. The outgroups used in our analysis are: *Alestes stuhlmannii* PFEFFER, *Astyanax aurocaudatus* EIGENMANN, *Brycon meeki* EIGENMANN & HILDEBRAND, *Bryconamericus caucanus* EIGENMANN, *Serrapinnus MALABARBA*, *Odontostilbe pulchra* (GILL), *Gephyrocharax caucanus* EIGENMANN, *Hemibrycon boquiae* (EIGENMANN), *Paracheirodon axelrodi* (SCHULTZ), *Pseudanos trimaculatus* (KNER) and *Spintherobolus ankoseion* WEITZMAN & MALABARBA (see material examined). We used available osteological and morphological descriptions of outgroups (WEITZMAN, 1962; WINTERBOTTOM, 1980; HOWES, 1982; WEITZMAN & MALABARBA, 1999; MURRAY, 2004; RUIZ-C. & ROMÁN-VALENCIA, 2006; BÜHRNHEIM & MALABARBA, 2007; SIDLAUSKAS & VARI, 2008). Sources of character states for other taxa, such as *Bryconamericus exodon* EIGENMANN, *Catapobrycon tucuruui* MALABARBA & VARI, *Creagrutus Varii* RIBEIRO, BENINE & FIGUEIREDO, *Cyanocharax MALABARBA & WEITZMAN*, *Myxiops aphos* ZANATA & AKAMA, *Roeboides* GÜNTHER, *Nematobrycon lacortei* WEITZMAN & FINK and some species of Cynopotaminae were also used (WEITZMAN, 1964; WEITZMAN & FINK, 1971; MENEZES, 1976; WEITZMAN & FINK, 1985; LUCENA, 1998; MALABARBA & VARI, 2000; MALABARBA & WEITZMAN, 2003; ZANATA & AKAMA, 2004; RIBEIRO *et al.*, 2004; SERRA & LANGEANI, 2006).

Phylogenetic analysis was done with Nona 2.0 (GOLOBOFF, 1993; 1998) through the Winclada 1.00.08 interface (NIXON, 2002) using maximum parsimony with exhaustive search. The multistate characters were coded as unordered. We used the tree-finding command "mswap+". To analyze ambiguous characters we used ACCTRAN optimization following PINNA (1991) and ZANATA & VARI (2005). We reported absolute frequencies of one bootstrap (FELSENSTEIN, 1985), with 500 replications to support each clade inside the cladogram. Conventional statistics were calculated: length of tree = LT; consistency index = IC; retention index = IR; rescaled consistency index = RC. We also reported cladogram length (l), consistency and retention index (ci and ri respectively) for each character. Some

characters (15, 31, 43, 44, 45 and 48) were uninformative with respect to the mentioned index.

Institutional abbreviations. The museum acronyms follow to LEVITON *et al.* (1985) and the ASIH list (online available on <http://asih.org/curation>); except for the fish collection from the Laboratorio Ictiología de la Universidad del Quindío, Armenia, Colombia (IUQ). In the material examined SL indicates standard length.

Biogeographical analysis. The procedures and methods used were developed by NELSON & PLATNICK (1980) and subsequently by MORRONE & CRISCI (1995), VAN VELLER *et al.* (1999; 2000) and MORRONE (2005).

We used a cladistic technique for reconstructing the ingroup biogeography. We used the following codes for the biogeographical analysis: *G. cochae* (1), *G. bogotensis* (2), *G. quitoensis* (3) and outgroups (4). The technique consisted of using the phylogeny proposed herein to construct the taxon-area and area cladograms. This distribution was based on ROMÁN-VALENCIA *et al.* (2003), BARRIGA & TERNAUS (2005) and ROMÁN-VALENCIA *et al.* (2005). A biogeographical hypothesis was inferred from the area cladogram and the historical geology of study areas. A map of *Grundulus* distribution was compared with the phylogeny to illustrate the data. Our biogeographic hypothesis assumed the proposed phylogeny and the following distribution ranges of the taxa analyzed: La Cocha coldwater lakes in the Amazon River basin (A, *G. cochae*); the Bogotá plateau in the Rio Magdalena basin (B, *G. bogotensis*); El Voladero coldwater lakes in the Mira River drainage, Pacific Ecuador (C, *G. quitoensis*). For the included outgroups we used the distributions of our examined material, where all of them were coded as (D). We rooted the area cladograms using the outgroups and considered their distributions as ancestral with respect to that of *Grundulus*.

Material examined

Ingroup

***Grundulus cochae*:** Colombia: (C&S) two specimens, 41.3–50.2 mm SL IUQ material in ROMÁN-VALENCIA *et al.* 2003. We also included alcohol preserved specimens cited in ROMÁN-VALENCIA *et al.* (2003). ***Grundulus bogotensis*:** Colombia: (C & S two specimens: 26.2–32.1 mm SL) IUQ material in ROMÁN-VALENCIA *et al.* (2003). We also included alcohol preserved specimens cited in ROMÁN-VALENCIA *et al.* (2003). ***Grundulus quitoensis*:** Ecuador: IUQ 532, (C&S) two specimens, 33.8–44.6 mm SL, Carchi province, El Voladero, coldwater lake, El Angel Biological Reserve (0° 40' N–77° 52' W), 3680 m, 20 July 2001. MEPN 1550, ten specimens, Carchi province, El Voladero, coldwater lakes, El Angel Biological Reserve (0° 40' N–77° 52' W),

3680 m, 20 July 2001. We also included alcohol preserved type specimens cited in ROMÁN-VALENCIA *et al.* (2005).

Outgroups

***Astyanax aurocaudatus*:** Colombia: IUQ 866, (C&S) four specimens (33.4–43.3 mm SL), Quindío, upper Cauca River drainage, La Siria Creek, tributary of Roble River, April 2001. IUQ 1526, 266 specimens, upper Cauca River drainage, La Siria Creek, tributary of Roble River, 30 September 2001. ***Bryconamericus caucanus*:** IUQ 868, (C&S) two specimens (54.5–65.5 mm SL), Antioquia, La Chinca Creek, tributary of Río Anori, 10 September 2003. IUQ 851, (C&S) five specimens (54.4–63.7 mm SL), Antioquia, Anori River, lower Cauca River drainage. IUQ 572, 50 specimens, Cauca River drainage, Zanjón Bagazal, road to Timba (3° 3' 59" N and 76° 33' 56" O), 19 August 1997. ***Brycon meeki*:** IUQ 690, eight specimens, Nariño, Tambo, Puerto Rico, Guaitara River at junction with Patia River. IUQ 1564, (C&S) three specimens (39.5–51.4 mm SL), Nariño, Tambo, Puerto Rico, Guaitara River at junction with Patia River. ***Gephyrocharax caucanus*:** IUQ 11, one specimen, Valle, San Marcos creek, tributary of La Paila River, on road to Sevilla-La Paila, 10 March 1994. IUQ 17, three specimens, San Pablo Creek, upper Cauca River drainage. IUQ 1214, (C&S) one specimen (36.4 mm SL), Valle, San Marcos Creek, tributary of La Paila River, on road to Sevilla-La Paila, 10 March 1994. ***Hemibrycon boquiae*:** IUQ 536, (C&S) two specimens (46.5–72.1 mm SL), Risaralda, Quinchia, Opirama, Río Opirama, Talabán Creek (5° 17' 47" N and 75° 45' 08" O), 1172 m, 18 October 2004. IUQ 301a, (C&S) four specimens (62.5–67.1 mm SL), Quindío, Salento, in Boquia Creek, tributary of Quindío River, 30 September 1998. IUQ 536, (C&S) two specimens (46.5–72.1 mm SL), Risaralda, Quinchia, Opirama, Opirama, River, Talabán Creek (5° 17' 47" N and 75° 45' 08" O), 1172 m, 18 October 2004. ***Odontostilbe pulchra*:** Venezuela: MBUCV 567, (C&S) two specimens (22.6–28.2 mm SL), Anzoátegui state, Pao River. ***Paracheirodon axelrodi*:** IUQ 1288 (ex MCNG 44272), two specimens, Amazonas state, Negro River drainage, forests flooded by Yaturá River (1° 28' 01" N y 66° 07' 84" O), 14 January 1999. IUQ 1290 (ex MCNG 44272), (C&S) one specimen (21.11 mm SL), Amazonas state, Negro River drainage, forests flooded by Yaturá River (1° 28' 01" N and 66° 07' 84" O), 14 January 1999. ***Serrapinnus sp.*:** IUQ 1287, (ex MCNG 34166) two specimens; Portuguesa state, Apure River drainage, Maraca Creek on Urriola farm, 5 August 1996. IUQ 1289 (ex MCNG 34166), (C&S) one specimen (28.1 mm SL); Portuguesa state, Apure River drainage, Maraca Creek on Urriola farm, 5 August 1996.

Character description and analysis

The character descriptions below were taken from the literature, or observed in specimens examined (see material examined and Table 1).

Dentary

1. Total number of teeth on each dentary. (0) fewer than eight; (1) eight or more. $l=2$, $ri=0.66$, $ci=0.50$.

Pseudanos WINTERBOTTOM, *Brycon* MÜLLER & TROSCHEL and *Alestes* MÜLLER & TROSCHEL have fewer than eight teeth on the dentary; other characids (e. g. *Bryconamericus* EIGENMANN and *Hemibrycon* GÜNTHER), Cheirodontinae and *Grundulus* have state 1.

2. Dentary tooth size variation. (0) with the anterior (first) teeth larger than the posterior; (1) with the anterior and posterior teeth of same size or if different, not as in state 0. $l=1$, $ri=1$, $ci=1$.

The generalized description of state 0 is that reported by WEITZMAN (1962: Fig. 10) for *Brycon meeki*; this distribution of dentary teeth was observed in *Pseudanos*, *Alestes*, *Astyanax* and *Paracheiroduon* GÉRY, among others. *Grundulus*, *Odontostilbe* Cope, *Serrapinnus*, and *Spintherobolus* have state 1.

3. Shape of dentary teeth. (0) multicuspid; (1) conical. $l=1$, $ri=1$, $ci=1$.

In *Brycon*, *Gephyrocharax* and *Astyanax* among other characids, the teeth are multicuspid. *Grundulus* has conical teeth.

4. Dentigerous border of the dentary (0) straight or convex; (1) concave or oblique. $l=1$, $ri=1$, $ci=1$.

Pseudanos has a reduced dentary (WINTERBOTTOM, 1980: Fig. 33); other taxa such as *Brycon*, *Astyanax* and *Bryconamericus* have the dentary approximately rectangular without a concave edge. State 1 was found in *Odontostilbe*, *Serrapinnus*, *Spintherobolus*, *Paracheiroduon* and *Grundulus*.

5. Dentary teeth. (0) not pedunculated; (1) with a proximal peduncle and an expanded and compressed distal region with several cusps. $l=1$, $ri=1$, $ci=1$.

WEITZMAN & MALABARBA (1999) and ZANATA & AKAMA (2004) discussed the condition described in this character, and its implications for Cheirodontinae. We only found state 1 in cheirodontine taxa examined.

6. Dentary. (0) approximately rectangular in shape or not as described for state 1; (1) forming an equilateral triangle with its anterior and posterior parts extremely slender, and the medial portion expanded just posterior to last tooth. $l=1$, $ri=1$, $ci=1$.

The outgroups analyzed have state 0. The dentary in *Grundulus* is different from all other taxa in our analysis (ROMÁN-VALENCIA et al., 2003: Fig. 4).

7. Size of foramen on lateral process and just above the ventral border of the dentary. (0) absent; (1) less of 25 % of length of dentary, (2) more of 25% of dentary.

Pseudanos and the other characid taxa have the state 0. *Spintherobolus ankoseion* has a large foramen on the ventral portion of the dentary (state 2), whereas *Grundulus* has a small foramen (state 1). However, this foramen should not be confused with the ventral foramen located under the teeth or other as the just located on the antero-dorsal part of Meckels cartilage (see WEITZMAN, 1962, Fig. 10).

8. Anguloarticular size relative to dentary. (0) overlaps less than half of the posterior part of dentary; (1) overlaps more or less half of the posterior part of the lateral dentary process. $l=1$, $ri=1$, $ci=1$.

State 0 was found in *Pseudanos*, *Brycon*, *Alestes*, *Astyanax*, *Hemibrycon*, *Bryconamericus* and *Gephyrocharax*. The anguloarticular bone has a distinctive condition among characid fish with a narrow dentary, that it is larger and more developed. Some examples of this condition occur within Xenobryconini (WEITZMAN & FINK, 1985). These fish have a large anguloarticular, but are not modified as in the Cheirodontinae taxa and *Grundulus* (state 1).

9. Anguloarticular. (0) irregular or not as in state 1; (1) with two horizontal processes originating from the same angle, where generally the upper process is more pronounced and larger than the lower process. These processes have a wavy or more or less sharp margin. $l=1$, $ri=1$, $ci=1$.

Pseudanos, *Brycon*, *Alestes*, *Astyanax*, *Hemibrycon*, *Gephyrocharax* and *Paracheiroduon* do not have the approximately triangular anguloarticular (state 0). *Grundulus* and cheirodontins have state 1.

Premaxilla

10. Tooth number in second (inner) row of premaxilla. (0) more than four; (1) three or four, (2) zero. $l=2$, $ri=1$, $ci=1$.

Because it is a multistate character it was difficult to determine the ancestral character state for the number of teeth in the second (inner) premaxillary row. *Pseudanos*, *Brycon* and *Alestes* have state 0. Characid taxa as *Astyanax*, *Hemibrycon*, *Gephyrocharax* and *Bryconamericus* have state 1. Four teeth in this row is a diagnostic character used by MALABARBA & WEITZMAN (2003) to characterize their "Clade A". *Grundulus*, cheirodontin taxa and *Paracheiroduon* have state 2.

11. Number of teeth in first (outer) row of premaxilla. (0) fewer than seven; (1) seven or more $l=3$, $ri=0.75$, $ci=0.5$.

Pseudanos, *Alestes*, *Astyanax*, *Hemibrycon*, *Bryconamericus*, *Gephyrocharax*, *Serrapinnus*, *Odontostilbe* and *Paracheirodon* have state 0. More than seven teeth on first row of premaxilla were found in *Brycon*, *Spintherobolus* and *Grundulus*.

12. Number of tooth rows in premaxilla. (0) three or more; (1) two, (2) one. $l=2$, $ri=1$, $ci=1$.

Brycon and *Alestes* have state 0. State 1 was found in *Pseudanos*, *Astyanax*, *Hemibrycon*, *Bryconamericus* and *Gephyrocharax*. *Grundulus*, *Paracheirodon* and Cheirodontinae have one row of teeth on the premaxilla. This is a derived state versus two or three rows (e. g. *Brycon* and other characid fish).

13. Premaxillary teeth type. (0) not conical; (1) conical. $l=1$, $ri=1$, $ci=1$.

Pseudanos, *Alestes*, *Brycon*, *Astyanax*, *Hemibrycon*, *Bryconamericus*, *Gephyrocharax*, *Paracheirodon*, *Serrapinnus* and *Odontostilbe* have the state 0. Conical teeth on the premaxilla were found in *Grundulus* and *Spintherobolus* (state 1). This condition was also reported in some Xenurobryconin (WEITZMAN & FINK, 1985: Figs. 61–64), but we considered that this character needs a more exhaustive search in other characids. It is important to note that in *Grundulus* the teeth of the dentary, maxilla and premaxilla, are conical.

14. Premaxillary teeth. (0) not pedunculated; (1) with a proximal peduncle and an expanded and compressed distal region with several cusps. $l=1$, $ri=1$, $ci=1$. (MALABARBA, 1998).

Pseudanos, *Brycon*, *Astyanax*, *Hemibrycon*, *Bryconamericus*, *Paracheirodon*, *Spintherobolus* and *Grundulus* have state 0. The presence of this character is a synapomorphy for cheirodontin taxa (*Odontostilbe* and *Serrapinnus*). A broad discussion of this condition is presented by MALABARBA (1998).

15. Processes of premaxilla articulating with maxilla. (0) absent; (1) short or reduced, (2) large or conspicuous. $l=2$, uninformative.

Pseudanos has state 0. Characid and cheirodontins have short processes (state 1). These processes are usually present in characids (e.g. Xenurobryconins; WEITZMAN & FINK, 1985). In *Alestes* they are more elongated, (state 2).

16. Premaxillary ascendant process oriented toward back (0) present; (1) absent. $l=1$, $ri=1$, $ci=1$.

All taxa analyzed except *Brycon* and *Alestes* have state 0.

Maxilla

17. Total number of teeth on maxilla. (0) Zero; (1) ranging from one to four, (2) ranging from five to ten, (3) more than ten. $l=4$, $ri=0.80$, $ci=0.75$.

Maxillary tooth loss is a condition observed in *Pseudanos* and *Alestes*. *Bryconamericus*, *Gephyrocharax*, *Serrapinnus*, *Odontostilbe* and *Paracheirodon* have state 1. *Astyanax*, *Hemibrycon*, *Spintherobolus* and *Grundulus* have a range from five to ten teeth on the maxilla (state 2).

18. Shape of maxillary teeth. (0) absent or not as other states (1) not conical; (2) conical. $l=3$, $ri=0.75$, $ci=0.66$.

Pseudanos and *Alestes* have state 0. *Brycon*, *Bryconamericus*, *Astyanax* among other taxa, presented cuspidate teeth on the maxilla (state 1). Conical teeth on the maxilla were found in *Grundulus* and *Spintherobolus* (state 2).

19. Number of notches on the lower lateral margin of maxilla (i.e. along its most expanded margin). (0) zero, (1) one; (2) two. $l=2$, $ri=1$, $ci=1$.

Pseudanos, *Brycon*, *Alestes* among other outgroups do not have these notches. The maxilla of *Grundulus* has distinctive notches (ROMÁN-VALENCIA *et al.*, 2003: Fig. 5). *G. cochae* and *G. bogotensis* have state 1. *G. quitoensis* has state 2.

20. Notch in the lower ventral margin of maxilla, just below of the dentigerous part. (0) absent; (1) present. $l=1$, $ri=1$, $ci=1$.

A maxilla with notches along the anterior border was found in *Grundulus*, but other taxa as *Pseudanos*, *Brycon*, *Alestes* among other outgroups do not have these notches.

21. Maxillary teeth. (0) not pedunculated; (1) with a proximal peduncle and an expanded and compressed distal region with several cusps. $l=1$, $ri=1$, $ci=1$.

The maxillary teeth of Cheirodontinae have a proximal peduncle and a highly compressed and expanded distal tip usually with several cusps (except in *Spintherobolus*) (For more details about this character see MALABARBA, 1998; WEITZMAN & MALABARBA, 1999). This condition was found in *Serrapinnus* and *Odontostilbe*. The other taxa analyzed (including *Grundulus*) have state 0.

Axial skeleton: neurocranium, opercular series and suspensory bones

22. Hyomandibular. (0) with wavy upper margin; (1) upper margin sloped, smooth or flat, not wavy. $l=1$, $ri=1$, $ci=1$.

The upper edge of the hyomandibular in *Pseudanos*, *Alestes*, *Brycon*, *Astyanax* among others, is wavy, has notches or small projections, but we have never observed a smooth upper edge. *Grundulus cochae* and *G. bogotensis* have state 1.

23. Number of infraorbitals. (0) Four or more; (1) fewer than four. $l=2$, $ri=0.66$, $ci=0.50$.

The majority of characiforms and most of the characids examined in this study have five or six infraorbitals. A reduction in the number of autogenous infraorbitals or a fusion of these elements resulting in one large bony element at the position of infraorbital 2 was reported for some Cheirodontinae (WEITZMAN & MALABARBA, 1999). *Grundulus* and *Paracheirodon* have state 1. In *Myxiops aphos* a reduction of infraorbitals also occurs; they have 3 to 5 elements (ZANATA & AKAMA, 2004).

24. Size of infraorbital 2 relatives to infraorbital 1. (0) Second infraorbital about same size as first; (1) second suborbital two to four times larger than first. $l=2$, $ri=0$, $ci=0.50$.

In *Pseudanos* and *Brycon* the size of second infraorbital is similar to the first. In *Grundulus* and other characids the second infraorbital is larger than first infraorbital (state 1).

25. Third infraorbital. (0) with ventral and posterior margins in contact with lateral margin of preopercle; (1) with ventral and posterior margins not contacting lateral margin of preopercle. $l=2$, $ri=0.66$, $ci=0.50$.

The absence of contact between the third infraorbital and preopercle is modified by the infraorbital number. *Grundulus* and *Astyanax* have state 1. The other taxa analyzed have state 0 or inapplicable.

26. Mesopterygoid. (0) short or not as in state 1; (1) long, with posterior part extended oval or round in shape, but with posterior margin curved. $l=1$, $ri=1$, $ci=1$.

The mesopterygoid in characids (e. g. *Astyanax*, *Bryconamericus* and *Paracheirodon*) has a typical condition, very similar to that described by WEITZMAN (1962) and SERRA & LANGEANI (2006) for *Brycon meeki* and *Bryconamericus exodon* respectively, but with some modifications in size and position. In *Grundulus* the mesopterygoid is very large and distinctive, oval or rounded in shape (state 1).

27. The lateral ethmoid extends ventrally aligned with the point of contact of the first and second infraorbitals. (0) absent; (1) present. $l=1$, $ri=1$, $ci=1$.

Pseudanos, *Alestes*, *Brycon*, *Astyanax*, *Hemibrycon* and *Bryconamericus* have state 0. The presence of this character was shared by *Gephyrocharax*, *Spintherobolus*,

Serrapinnus, *Odontostilbe*, *Paracheirodon* and *Grundulus*.

28. Opercle with smooth, more or less flat dorsal border and extending antero-posteriorly with a pronounced curved shape, or hump, located in the middle part. (0) absent; (1) present. $l=1$, $ri=1$, $ci=1$.

An opercle with a hump on its dorsal margin is absent from most characid fishes. We believe that a smooth dorsal opercular margin is the primitive condition within our hypothesis and that state 1 is a derived condition, found in some cheirodontins, *Paracheirodon* and *Grundulus*.

29. Opercle. (0) with a smooth or flat upper margin; (1) with upper margin curved. $l=1$, $ri=1$, $ci=1$.

The opercle with a curved upper margin is present in *Alestes* and *Brycon*. In *Pseudanos* this bone is expanded posteriorly, with a smooth upper margin. Other characids have state 0 (e. g. *Grundulus*).

Vertebrae

30. Total vertebral number, including the four from Weberian apparatus (0) 35 or more; (1) fewer than 35. $l=2$, $ri=0.75$, $ci=0.50$.

Taxa such as *Pseudanos*, *Brycon* among other characid fish have 35 or more vertebrae. A reduced vertebrae number was found in *Spintherobolus*, *Paracheirodon* and *Grundulus*.

Intermuscular bones

31. Epineurals. (0) present; (1) absent. $l=1$, uninformative.

Absence of epineurals was found only in *Grundulus quitoensis*.

32. Epipleurals. (0) present; (1) absent. $l=1$, uninformative.

Absence of epipleurals was found only in *Grundulus quitoensis*.

33. Number of epineurals. (0) 40 or more; (1) ranging from 30 to 39, (2) fewer than 30. $l=2$, $ri=1$, $ci=1$. *Brycon* has state 0. *Pseudanos*, *Alestes*, *Astyanax*, *Hemibrycon*, *Bryconamericus*, *Gephyrocharax*, *Spintherobolus*, *Serrapinnus*, *Odontostilbe*, *Paracheirodon* and *Grundulus quitoensis* have either state 0 or inapplicable (=?). The reduced number of epineurals (state 2) was shared by *Grundulus cochae* and *G. bogotensis*.

34. Number of epipleurals. (0) 20 or more; (1) ranging from 15 to 19, (2) fewer than 15. $l=2$, $ri=1$, $ci=1$.

The reduced number of epipleurals was shared by *Grundulus cochae* and *G. bogotensis*. *Serrapinnus*, *Odontostilbe* and *Paracheirodon* have state 1. A high number of epineurals was found in *Brycon*, *Alestes*, *Astyanax*, and *Bryconamericus* among other taxa.

Pectoral girdle

35. Coracoids (0) not triangular in shape or not as in state 1; (1) approximately triangular in shape, with anterior portion more expanded and smooth; posterior extreme slender and more acute when extend to cleithrum. $l=1$, $ri=1$, $ci=1$.

The coracoids in characid fishes (e.g. *Brycon*, *Alestes*, *Hemibrycon*, *Bryconamericus* and other outgroups) are approximately rectangular. They are very different in *Grundulus* (approximated triangular shape) and *Spintherobolus* (more or less discoid shape). *Grundulus* has state 1.

36. Supracleithrum. (0) base rounded, or not as in state 1; (1) base slender, its tip elongated and flattened and anterior portion with lamellar process. $l=1$, $ri=1$, $ci=1$.

The common supracleithrum shape pattern in characid fishes (e. g. *Astyanax*, *Bryconamericus* and *Hemibrycon*) is found in *Brycon* (WEITZMAN, 1962). A supracleithrum with a slender base and a winged anterior portion is a derived condition found in both *Grundulus cochae* and *G. bogotensis*. The state 0 was observed in other taxa.

Pelvic fins

37. Foramen on the base of isquiatic process. (0) absent; (1) present.

Grundulus cochae and *G. bogotensis* have a foramen on the base of isquiatic process; no outgroups had this state. $l=1$, $ri=1$, $ci=1$.

38. Posterior part of ischiatic process cartilaginous. (0) absent; (1) present. $l=2$, $ri=0.80$, $ci=0.50$.

Pseudanos, *Brycon*, *Alestes* among other taxa have state 0. The presence of this character was found among several taxa: *Grundulus quitoensis*, *Paracheirodon*, *Bryconamericus*, *Gephyrocharax*, *Spintherobolus*, and *Serrapinnus*.

39. Anterior tip of pelvic bone. (0) short and wide; (1) long and slender, coming to point. $l=1$, $ri=1$, $ci=1$. In the typical condition for Characidae the pelvic bone has an expanded and wide anterior process (WEITZMAN, 1962: Fig. 21). This condition was found in *Astyanax*, *Bryconamericus* and *Hemibrycon* among others. *Grundulus* have state 1.

40. Length of anterior tip of pelvic bone is at least one time longer (sometimes close to two times) than length of posterior portion. (0) absent; (1) present. $l=1$, $ri=1$, $ci=1$.

Grundulus is the only examined taxon where the length of anterior process of pelvic bone was one or two times longer than the posterior portion of the anterior process.

41. Length of pelvic anterior extreme (see ROMÁN-VALENCIA *et al.* 2003). (0) fewer than six times longer than width of medial portion, (1) ranging from six to nine; (2) ten or more. $l=5$, $ri=0.40$, $ci=0.40$.

Pseudanos, *Alestes*, *Spintherobolus* and *Odontostilbe* have state 0. *Brycon*, *Astyanax*, *Hemibrycon*, *Bryconamericus*, *Gephyrocharax*, *Serrapinnus* and *Paracheirodon* have state 1. *Grundulus* has state 2.

Dorsal fins and supraneurals

42. Number of supraneurals. (0) Seven or more; (1) fewer than seven. $l=3$, $ri=0.33$, $ci=0.33$.

State 0 is found in *Brycon*, *Hemibrycon*, *Bryconamericus*, *Gephyrocharax* and *Grundulus*. *Astyanax*, *Serrapinnus*, *Odontostilbe* and *Paracheirodon* has state 1.

43. Number of rays in dorsal fin. (0) iii–iv, 9–11; (1) i–iii, 6–9. $l=1$, uninformative.

Pseudanos was the only taxon with iii–iv, 9–11 rays in dorsal fin. State 1 is derived for other taxa (included *Grundulus*).

44. Proximal rays in dorsal fin. (0) with keel; (1) without keel. $l=1$, uninformative.

Anal fins

45. First pterygiophores of anal fin. (0) wide or expanded; (1) slender. $l=1$, uninformative.

WEITZMAN and MALABARBA (1999) stated that *Grundulus bogotensis* had a short and not elongated anterior pterygiophores in the anal fin (see ROMÁN-VALENCIA *et al.*, 2003: Fig. 3). We found that this character is an autapomorphy for this species and it is not a synapomorphy for genus. The other *Grundulus* species have wide and elongate proximal pterygiophores as in most characids (e. g. *Brycon*, *Astyanax*, *Gephyrocharax*, *Paracheirodon*, Cheirodontinae among other taxa); we believe that it is a plesiomorphy (state 0).

46. Number of proximal pterygiophores in anal fin. (0) fewer than ten; (1) ranging from eleven to 14, (2) 15 or more. $l=2$, $ri=1$, $ci=1$.

Pseudanos has fewer than ten anal rays. A range from eleven to 14 was found in *Spintherobolus* and *Grundulus* (state 1). *Brycon*, *Alestes*, *Astyanax*, *Hemibrycon*, *Bryconamericus*, *Gephyrocharax*, *Serrapinnus*, *Odontostilbe* and *Paracheirodon* have state 2.

Adipose fin

47. Adipose fin. (0) present; (1) absent. $l=1$, $ri=1$, $ci=1$.

Pseudanos, *Brycon* and other characid taxa have an adipose fin. *Spintherobolus* and *Grundulus* lack an adipose fin. The loss of adipose fin supports some nodes in our hypothesis, but we believe that this character is only informative at some levels of comparison (see FINK & FINK, 1981 and WEITZMAN & MALABARBA, 1999).

Caudal fin

48. Number of hypurals. (0) six or more; (1) fewer than six. $l=1$, uninformative.

The common state distributed among our outgroups is the presence of six or more hypurals (including *Grundulus cochae* and *G. bogotensis*). *G. quitoensis* has a reduced number of hypurals (state 1).

49. Number of epurals. (0) three or more; (1) fewer than three. $l=1$, $ri=1$, $ci=1$.

Pseudanos, *Brycon* and *Alestes* have state 0. Fewer than three epurals was the condition shared for *Grundulus*, *Paracheirodon*, *Gephyrocharax*, cheirodontin fish, *Bryconamericus*, *Astyanax*, and *Hemibrycon*.

50. Hole located near angle formed between parhypural and urostyl. (0) square or rectangle; (1) rounded. $l=1$, $ri=1$, $ci=1$.

A more or less square or rectangle shape (state 0) was found in *Pseudanos*, *Alestes*, characid fishes and cheirodontin fishes (*Spintherobolus* has state inapplicable or?). In *Grundulus* the hole is rounded; it is located just in the angle where the parhypural and urostyl are extended.

51. Caudal fin. (0) middle caudal-fin rays much shorter than those of upper and lower lobes; (1) middle caudal-fin lobes about same length as those of upper and lower lobes. $l=1$, $ri=1$, $ci=1$.

The outgroups analyzed (e. g. *Pseudanos*, *Brycon*, *Astyanax*) have both caudal lobes much narrow, sometimes the lower lobe is more pronounced than the upper. *Grundulus* has a distinctive caudal fin (approximately round), because the central rays are about as long as those of the upper and lower lobes.

Scales

52. Lateral line. (0) complete, or if reduced with eight or more perforated scales; (1) fewer than eight perforated scales. $l=2$, $ri=0.75$, $ci=0.50$.

In Characiformes (e. g. *Brycon*) the lateral line is usually complete, or if reduced, it has eight or more perforated scales. *Spintherobolus*, *Paracheirodon* and *Grundulus* have a comparatively more reduced number of scales in the lateral line (1).

53. Number of perforated lateral-line scales. (0) two or more (1) zero or absent; $l=1$, $ri=1$, $ci=1$.

A complete lateral line is present in all outgroups except *Paracheirodon*. We observed in *Grundulus* a loss or reduction in the number of perforated lateral line scales. However, *Spintherobolus* presented a similar condition, but in our criteria it does not have a complete loss.

Other structures

54. Muscle hiatus lateral to anterior portion of the swim bladder, between the first and second pleural ribs (sensu MALABARBA, 1998: 109). (0) absent; (1) present. $l=2$, $ri=0.50$, $ci=0.50$.

Grundulus and most taxa other than Cheirodontinae have state 0. We believe that a hiatus has arisen more than once within Characidae. However, WEITZMAN & MALABARBA (1999) discussed this character state more extensively. The presence of a muscle hiatus was found in the cheirodontins. In *Paracheirodon* we observed a muscle hiatus that does not correspond to that described by MALABARBA (1998); possibly this would be analyzed in detail. The region between the first and second pleural rib was converted by muscle and no hiatus sensu MALABARBA (1998) was found.

Pigmentation

55. Humeral spot. (0) absent; (1) well separated from the opercle; (2) located just behind opercle, almost touching this bone. $l=2$, $ri=1$, $ci=1$.

The absence of humeral spot was found in cheirodontin fishes; as stated by MALABARBA (1998). *Grundulus* has a very distinctive humeral spot; this black spot is located just behind and in contact with the opercle; sometimes it is more or less close to the pectoral girdle bones (state 2).

Results

Phylogenetic analysis. We obtained one most parsimonious tree with the exact algorithm (Figs. 1 and 2) with a length of 84 steps, consistency index of 0.80, retention index of 0.88 and rescaled consistency index of 0.70 (without autapomorphies from binary characters: LT=79, IC=0.79, IR=0.88, RC=0.69). The absolute frequencies are high (greater than 0.50), showing good support for the proposed relationships (Fig. 1 and 2). We found that *Grundulus* is more related to genera included in Cheirodontinae than other outgroups of fishes used in our analysis (Fig. 1). *Spintherobolus* was the taxa closest to *Grundulus*. The genus *Paracheirodon* was more related with cheirodontins and *Grundulus*. With this comparative analysis we identified four informative nodes for the phylogeny of *Grundulus* species supported by synapomorphies (Fig. 2).

Node A (Relationships between Cheirodontinae and *Grundulus*)

From the mentioned phylogeny we propose the following five synapomorphies:

1. Dentary tooth size not variable, anterior and posterior teeth of same size (character 2, state 1).
2. Anguloarticular overlaps more or less half of the dentary lateral process (character 8, state 1).
3. Anguloarticular with two anterior processes originating in the same angle, where generally the upper process is more pronounced and larger than the lower process. These processes have a wavy or more or less acute edge (character 9, state 1).
4. Muscle hiatus lateral to anterior portion of the swim bladder, between the first and second pleural ribs (character 54, state 1). Optimized by ACCTRAN.
5. Humeral spot absent (character 55, state 0). The state 0 was a derived condition between 1 and 2. We noted that *Serrapinnus*, *Odontostilbe* and *Spintherobolus* were the only taxa lacking the humeral spot.

Homoplasies:

1. Third infraorbital with ventral and posterior edges not in contact with lateral margin of preopercle (character 25 state 1). Optimized by ACCTRAN.
2. Length of anterior pelvic process fewer than six times longer than width of medial portion (character 41, state 0). Optimized by ACCTRAN.

Node B (*Spintherobolus* and *Grundulus*)

Nine synapomorphies supported this node:

1. Small foramen above the ventral portion of the dentary (character 7, state 1). Optimized by ACCTRAN.
2. Conical teeth on premaxilla (character 13, state 1).
3. Conical teeth on maxilla (character 18, state 2).
4. Ectopterygoids large with a round or oval posterior extension and a curved posterior margin (character 26, state 1). Optimized by ACCTRAN.
5. Fewer than 30 epineurals (character 33, state 2). Optimized by ACCTRAN.
6. Fewer than 15 epipleurals (character 34, state 2). Optimized by ACCTRAN.
7. Proximal anal-fin pterygiophores ranging from eleven to 14 (character 46, state 1).
8. Adipose fin absent (character 47, state 1).
9. Approximately round hole located just in angle formed by extensions of the parhypural and urostyl (character 50, state 1). Optimized by ACCTRAN.

Homoplasies:

1. More than seven teeth in first row of premaxilla (character 11, state 1).
2. More than ten teeth on the maxilla (character 17, state 2).
3. Seven or more supraneurals (character 42, state 0). Optimized by ACCTRAN.

Node C (*Grundulus* monophyly)

The *Grundulus* monophyly was supported by eleven synapomorphies.

1. Dentary teeth conical (character 3, state 1).
2. Dentary forming an equilateral triangle with its anterior and posterior parts extremely slender, and the medial portion more expanded just behind last tooth (character 6, state 1).
3. One notch on the lateral lower border of maxilla (i.e. along its most expanded extreme) (character 19, state 1). Optimized by ACCTRAN.
4. Notch in the lateral lower surface of maxilla, just below the dentigerous part (character 20, state 1).
5. Coracoids approximately triangular in shape, with anterior portion more expanded and smooth, sometimes with cartilage; posterior extreme slender, more acute and reduced in size when is extend to cleithrum (character 35, state 1).
6. Anterior extreme of pelvic bone long and slender, with fine anterior tip (character 39, state 1).

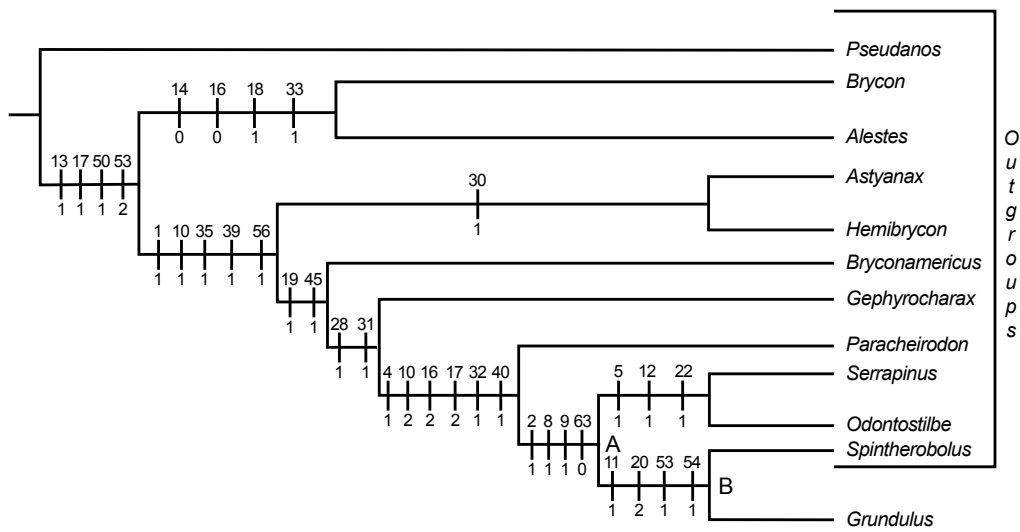

Fig. 1. Cladogram of the most parsimonious hypothesis of relationships for ingroup and outgroups (numbered characters correspond to those in text, above black and white circles). Black circles = derived homologies; white circles = homoplastic characters; the numbers in the upper and lower parts correspond to the number of the character and state respectively. Both A and B, correspond to nodes explained in text. LT = 84, IC = 0.80, IR = 0.88 and RC = 0.70. The numbers in each node correspond to absolute frequencies from the bootstrap analysis.

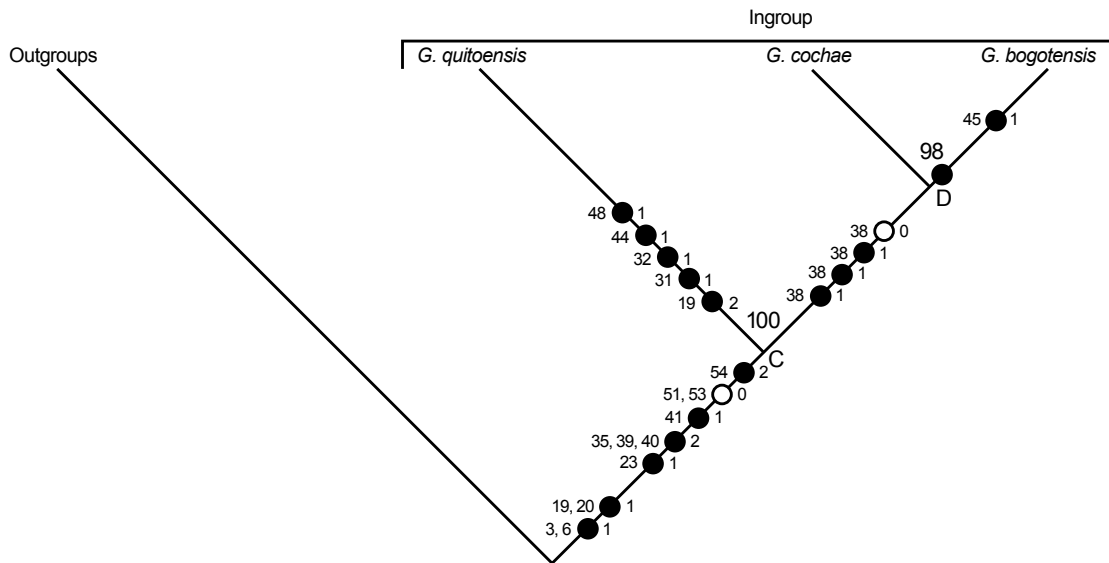

Fig. 2. Cladogram of the most parsimonious hypothesis of relationships within *Grundulus* species (numbered characters correspond to those of the text). Black circles = derived homologies; white circles = homoplastic characters; the numbers in the left and right parts correspond to the number of the character and state respectively. C and D correspond to nodes explained in text. LT = 84, IC = 0.80, IR = 0.88 and RC = 0.70. The numbers in each node correspond to absolute frequencies from the bootstrap analysis.

- 7. The length of anterior extremity of pelvic bone is one time larger (sometimes close to two times) than width of its posterior portion (character 40, state 1).
- 8. Ranging from ten or more times the length of anterior extreme of pelvic bone is bigger than its width on medial portion (character 41, state 2). Optimized by ACCTRAN.
- 9. The caudal lobes stout or broad; the middle rays about same length as others (character 51, state 1).
- 10. Pored lateral-line scales zero or one (character 53, state 1).
- 11. Humeral spot located just behind opercle and in contact with this bone (character 55, state 2). Optimized by ACCTRAN.

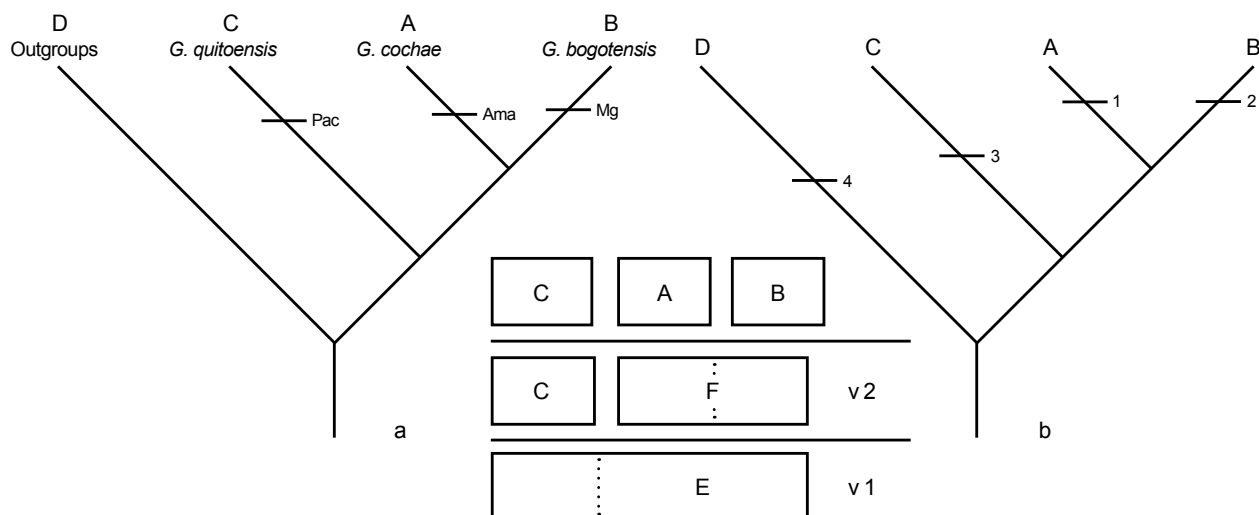

Fig. 3. Taxon–area (a) and area (b) cladograms obtained from the phylogeny. Pac: Pacific, Ama: Amazonas and Mg: Magdalena. La Cocha coldwater lake on Amazonas basin (=A, *Grundulus cochae*: 1), The Bogotá plateau on Magdalena basin (=B, *G. bogotensis*: 2), El Voladero coldwater lakes on Rio Mira, eastern from Pacific (=C, *G. quitoensis*: 3) and geographic distribution of outgroups (=D, 4). This represents a sequence of vicariance-events successively subdividing a continuous ancestral area into smaller components (c). Ancestral areas: where E represented C+A+B together and F represented to A+B together (b). v1: illustrates the first vicariant event, v2: illustrates the second vicariant event.

Homoplasies:

1. Fewer than four infraorbitals (character 23, state 1).
2. Without muscle hiatus lateral between the first and second pleural ribs (character 54, state 0). Optimized by ACCTRAN.

Node D (Relationships between *G. cochae* and *G. bogotensis*)

This node was supported by three synapomorphies. A close relationship was more evident between *G. cochae* and *G. bogotensis* than between *G. quitoensis* and either of those. Thus, *G. quitoensis* was identified as a possible group sister for these two species.

1. Hyomandibular with sloped, smooth or flat upper edge, not wavy (character 22, state 1).
2. Supracleithrum with slender base, its tip elongated and flattened; anterior portion with lamellar process (character 36, state 1).
3. Foramen at base of ischial process (character 37, state 1).

Homoplasies:

1. Without cartilage at posterior end of ischiatic process (character 38, state 0).

Autapomorphies. Within node B six autapomorphies were found for *Grundulus quitoensis*: characters 19 (state 2, ACCTRAN), 31, 32, 44 and 49 (each with state 1, Fig. 2). While *G. bogotensis* has one autapomorphy (character 45).

We found *Grundulus* to be more related to Cheirodontinae, but this genus does not share all diagnostic characters of that subfamily. Thus, we propose that Cheirodontinae is close to *Grundulus*, but that this distinctive genus should be further compared in a more ample study to reveal its phylogenetic position within Characidae.

Biogeography analysis

Cladistic biogeography: The analysis of geographic distribution showed that *Grundulus* is an endemic genus from the Andes mountains, restricted to coldwater lakes from Northern South America. The taxon-area cladogram was supported by the high consistency found between the areas and phylogeny of taxa, wherein each area harbored a particular species (Fig. 3a). However, we observed the same pattern between the taxon-area cladogram and the area cladogram (Fig. 3b). Therefore the areas most closely related were La Cocha coldwater lake (Amazonas basin, A) and the Bogotá plateau (Rio Magdalena basin, B). In addition, the Pacific Andean mountains region on Ecuador was the sister area for A and B. Moreover, it is possible to assume that based on phylogeny, the Bogotá plateau is the most recent area, even though this assertion cannot be confirmed through cladistic biogeography method since this assumption is a premise from phylogenetic biogeography. The cladograms obtained are congruent with the first-order

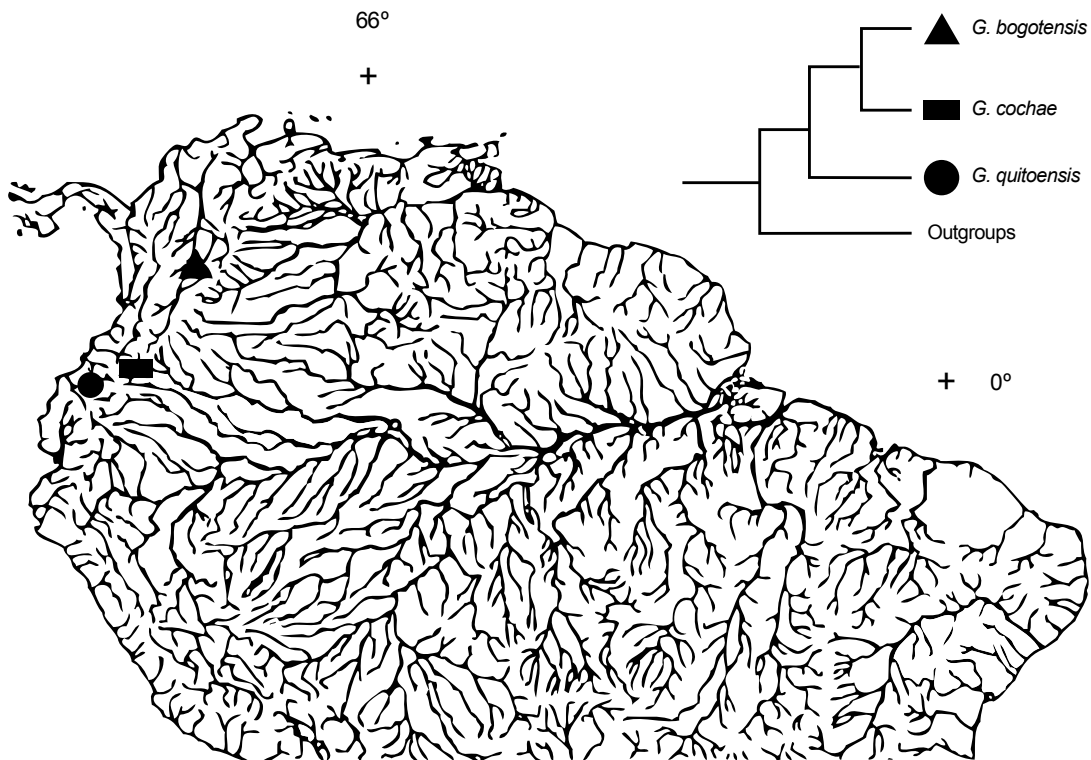

Fig. 4. Northern South America, showing the geographic distribution of *Grundulus* species.

explanation in cladistic or vicariance biogeography, indicating that the pattern obtained was due to vicariance (Figs. 3 and 4).

Discussion

Phylogeny: We conclude that *Grundulus* is monophyletic, but, none previous studies on the phylogenetic relationships within Characidae (WEITZMAN & MALABARBA, 1999; MALABARBA & WEITZMAN, 2003; REIS *et al.*, 2003; WEITZMAN *et al.*, 2005) and included to *Grundulus* has been concluded same. However, MIRANDE (2009) observed a close relationship of *Grundulus* with the genera *Coptobrycon* GÉRY and *Gymnocharacinus* STEINDACHNER, we suppose his results would be used to reoptimize the node at level of clade of *Grundulus*, including these genera in a future analysis. We found that *Grundulus* is more related to *Spintherobolus* than any other outgroup used. This result is concordant with comments of EIGENMANN (1915) and GÉRY (1977) regarding these genera.

Some characters analyzed by WEITZMAN & MALABARBA (1999) are significant for the systematics of the genus. They reported that reductive features were independently acquired by *Grundulus* and *Spintherobolus* (e.g. lateral line perforating only with 1–6 scales and adipose fin lacking). Moreover, they proposed that a

single row of teeth on the premaxilla appeared many times in the Characidae and some other Characiformes; while a reduced number of anal-fin rays in *G. bogotensis* were hypothesized to be derived. We did not find the reduced number of anal-fin rays to be phylogenetically informative for *Grundulus*. In addition, according to results of WEITZMAN & MALABARBA (1999), the small number of perforated lateral-line scales appears independently derived according to the most parsimonious hypothesis. In our results both one row of teeth on premaxilla and a reduced number of perforated scales on lateral line were derived characters and were useful to support some nodes. The loss of the adipose fin, as occur in *Grundulus*, has occurred several times within hypothesized independent clades of characiforms. Loss of this fin is correlated with small to miniature size for some characiform genera. However, these features are not always associated with miniature size (e.g., *Lebiasina* VALENCIENNES and *Hasemanina* ELLIS; WEITZMAN & MALABARBA, 1999).

We corroborated synapomorphies traditionally used to diagnose *Grundulus* and present additional characters useful to identify the genus. For example, we corroborated the observation made by EIGENMANN (1915) that *Grundulus* species lack predorsal scales, a character that has proved to be very useful with regards to their taxonomy and of wider significance in the context of Characidae phylogenetics. Moreover, we confirm the absence of supraorbital in all species of *Grundulus*.

is better explained in detail by VAN DER HAMMEN (1992, 2000) and EUSCATEGUI (2002). They argued that these lakes possibly were formed during the glacial period (Quaternary until the end of Neoglacial). We suppose that *Grundulus* was completely isolated when the glaciations occurred. Thus, the climate changes forced populations to disperse into more favorable regions, possibly highlands.

We believe that there is a mistake in the Amazonian-Colombia fish list by BOGOTÁ-GREGORY & MALDONADO-OCAMPO (2006: 66), included *G. bogotensis*. Our results show that *G. bogotensis* is only present on the Bogotá plateau, of the Magdalena River Basin (ROMÁN-VALENCIA *et al.*, 2003).

Acknowledgements

We thank the following persons for the loan of specimens: D.C. TAPHORN (MCNG), R. BARRIGA (MEPN) and F. PROVENZANO (MBUCV). P. PETRY, W.L. FINK, J. ARMBRUSTER, D. TAPHORN and D.J. STRAW for improving the grammar and providing some comments on our English. Corrections and criticism were provided by J.J. MORRONE, R. ROYERO, W.L. FINK, J. ARMBRUSTER, C.A. GARCIA, P. PETRY, D. TAPHORN and two anonymous revisors.

References

- ALBERT, J.S., LOVEJOY, N.R. & CRAMPTON, W.G.R. (2006): Miocene tectonism and the separation of cis- and trans-Andean river basins: Evidence from neotropical fishes. – *Journal of South American Earth Sciences*, **21**: 14–27.
- BARRIGA, R.S. & TERNAUS, E. (2005): Primer hallazgo de una población paleoendémica del pez *Grundulus* cf. *bogotensis* (HUMBOLDT, 1821) en los altos Andes del Ecuador. – *Politécnica*, **26**: 1–13.
- BOGOTÁ-GREGORY, J.D. & MALDONADO-OCAMPO, J.A. (2006): Peces de la zona hidrográfica de la Amazonia, Colombia. – *Biota Colombiana*, **7**(1): 55–94.
- BÜHRNHEIM, C.M. & MALABARBA, L.R. (2007): Redescription of *Odontostilbe pulchra* (GILL, 1858) (Teleostei: Characidae: Cheirodontinae), and description of two new species from río Orinoco basin. – *Neotropical Ichthyology*, **5**(1): 1–20.
- CALCAGNOTTO, D., SCHAEFER, S.A. & DESALLE, R. (2005): Relationships among characiform fishes inferred from analysis of nuclear and mitochondrial gene sequences. – *Molecular Phylogenetics and Evolution*, **36**: 135–153.
- CUVIER, M.B. & VALENCIENNES, M.A. (1846): Histoire naturelle des poissons. Suite du livre dix huitième Cyprinoides. Livre dix neuvième. – Des Esoces ou licioides, **18**: 216–220.
- DAHL, G. (1971): Los peces del norte de Colombia. – Inderena, Bogotá, 391 pp.
- DIAZ DE GAMERO, M.L. (1996): The changing course of the Orinoco river during the neogene: a review. – *Palaeogeography, Palaeoclimatology, Palaeoecology*, **123**: 385–402.
- DUQUE-CARO, H. (1990): The Choco block in the northwestern corner of South America: structural, tectonostratigraphic, and paleogeographic implications. – *Journal of South American Earth Sciences*, **3**(1): 71–84.
- EIGENMANN, C.H. (1915): The Cheirodontinae, a subfamily of minute characid fishes of South America. – *Memoirs of the Carnegie Museum*, **7**: 1–99, pls 1–17.
- EIGENMANN, C.H. (1922): The fishes of the northwestern south America including Colombia, Panama and Pacific slopes of Ecuador and Peru, together with appendix upon the fishes of the Rio Meta in Colombia. – *Memoirs of the Carnegie Museum*, **9**(1): 1–348.
- EUSCATEGUI, C.F. (2002): Estados de los glaciales en Colombia y análisis de la dinámica glaciaria en el parque los Nevados, asociada al cambio climático global. – M. Sc. Thesis, Universidad Nacional de Colombia, Bogotá, 286 pp.
- FELSENSTEIN, J. (1985): Confidence limits on phylogenies: an approach using the bootstrap. – *Evolution*, **39**: 783–791.
- FINK, S.V. & FINK, W.L. (1981): Interrelationships of the ostariophysan fishes (Teleostei). – *Zoological Journal of the Linnean Society*, **72**: 297–353.
- GÉRY, J. (1977): Characoids of the world. – tfh-Publications, Neptune City, 672 pp.
- GOLOBOFF, P.A. (1993): Nona, v. 2.0, version 2.0. Available from <http://www.cladistics.com/> (accessed 27 December 2008).
- GOLOBOFF, P.A. (1998): Principios básicos de cladística. – Sociedad Argentina de Botánica, Buenos Aires, 81 pp.
- GÓMEZ, E., JORDAN, T.E., ALLMENDINGER, R.W., HEGARTY, K. & KELLEY, S. (2005): Syntectonic cenozoic sedimentation in the northern middle Magdalena valley basin of Colombia and implication for exhumation of the northern andes. – *Geological Society of America Bulletin*, **117**(5–6): 547–569.
- GREGORY-WODZICKI, M.K. (2000): Uplift history of the central and northern andes: A review. – *Geological Society of America Bulletin*, **112**(7): 1091–1105.
- HAFER, J. (1979): Quaternary biogeography of tropical lowland South America. In: Duellmann W.E. (ed.): *The South American Herpetofauna; its origin evolution and dispersal*. Museum Natural University Kansas Monogr., **7**: 107–140.
- HENNIG, W. (1966): *Phylogenetic systematics*. – University of Illinois Press, Chicago, 263 pp.
- HERNÁNDEZ, C.J., HURTADO, G.A., ORTIZ, Q.R., & WALSCHBURGER, T. (1992a): Centros de endemismo en Colombia. In: Halffter, G. (Comp.), *Diversidad Biológica*

- de Iberoamérica I. – Acta Zoología Mexicana (Volumen especial), pp. 175–190.
- HERNÁNDEZ, C.J., WALSCHBURGER, T.; ORTIZ, Q.R. & HURTADO, G.A. (1992b): Origen y distribución de la biota Suramericana y Colombiana. – In: Halffter, G. (Comp.), *Diversidad Biológica de Iberoamérica I.* – Acta Zoología Mexicana (Volumen especial), pp. 55–104.
- HOORN, C. (1994): An environmental reconstruction of the palaeo-Amazon River system (Middle-Late Miocene, NW Amazonia). – *Palaeogeography, Palaeoclimatology, Palaeoecology*, **112**: 187–238.
- HOORN, C.; GUERRERO, J.; SARMIENTO, G.A. & LORENTE, M.A. (1995): Andean tectonics as a cause for changing drainage patterns in miocene northern South America. – *Geology*, **23**(3): 237–240.
- HOWES, G. (1982): Review of the genus *Brycon* (Teleostei: Characoidei). – *Bulletin of the British Museum of Natural History (Zoology)*, **43**(1): 1–47.
- HUBERT, N. & RENNO, J.F. (2006): Historical biogeography of South American freshwater fishes. – *Journal of Biogeography*, **33**: 1414–1436.
- HUMBOLDT, A. VON & VALENCIENNES, A. (1833): Reserches sur les poissons fluviatiles de l'Amérique equinoxiale. – In: HUMBOLDT, F.H.A. VON et A. BONPLAND, d' observations de zoologie et d'anatomie Comparée. – Paris, **2**: 159 pl 45, fig. 1. pp. 154–159.
- LAMB, S. & DAVIS, P. (2003): Cenozoic climate change as a possible cause for the rise of the Andes. – *Nature*, **425**: 792–797.
- LEVITON, A.E.; GIBBS, JR. R.H.; HEAL, E. & DAWSON, C.E. (1985): Standards in herpetology and ichthyology: Part I. Standard symbolic codes for institutional resource collections in herpetology and ichthyology. – *Copeia*, **1985**(3): 802–832.
- LOVEJOY, N.R.; ALBERT, J.S. & CRAMPTON, W.G.R. (2006): Miocene marine incursions and marine/freshwater transitions: Evidence from neotropical fishes. – *Journal of South American Earth Sciences*, **21**: 5–13.
- LUCENA, C.A.S. (1993): Estudo filogenético da família Characidae com uma discussão dos grupos naturais propostos (Teleostei, Ostariophysi, Characiformes). – Ph.D.Thesis, Universidad de São Paulo, Brazil, 158 pp.
- LUCENA, C.A.S. (1998): Relações filogenéticas e definição do gênero *Roeboidea* GÜNTHER (Ostariophysi: Characiformes: Characidae). – *Comunicações do Museu de Ciências e Tecnologia da PUCRS, Série Zoologia, Porto Alegre*, **11**: 19–59.
- LUNDBERG, J.G. (1997): Freshwater fishes and their paleobiotic implications. – In: KAY, R.F., MADDEN, R.H., R.L. CIFELLI & FLYNN, J.J. (Eds.), *Vertebrate paleontology in the neotropics: The Miocene fauna of La Venta, Colombia.* – Smithsonian Institution Press, Washington y London, pp. 67–91.
- LUNDBERG, J.G. (1998): The temporal context for the diversification of neotropical fishes. – In: MALABARBA, L.R., REIS, R.E., VARI, R.P., De LUCENA, Z.M.S. & LUCENA, C.A.S. (Eds.), *Phylogeny and classification of neotropical fishes.* – Edipucrs, Porto Alegre, pp. 49–68.
- LYNCH, J.D. (1988): Refugia. – In: MYERS, A.A. & GILER, P.S. (Eds.), *Analytical Biogeography: An integrated approach to study of animal and plants distributions.* – Chapman and Hall, London–New York, pp. 311–342.
- MALABARBA, L.R. (1998): Monophyly of the Cheirodontinae: Characters and major clades (Teleostei: Characidae). – In: MALABARBA, L.R., REIS, R.E., VARI, R.P. De LUCENA, Z. M. S. & LUCENA, C.A.S. (Eds.), *Phylogeny and classification of Neotropical fishes.* – Edipucrs, Porto Alegre, pp. 193–233.
- MALABARBA, L.R. & VARI, R.P. (2000): *Caiapobrycon tucuruí*, a new genus and species of characid from the rio Tocantes basin, Brazil (Characiformes: Characidae). – *Ichthyological Exploration of Freshwaters*, **11**(4): 315–326.
- MALABARBA, L.R. & WEITZMAN, S.H. (2003): Description of new genus with six new species from southern Brazil, Uruguay and Argentina, with a discussion of a putative characid clade (Teleostei: Characiformes: Characidae). – *Comunicações do Museu de Ciências e Tecnologia da PUCRS, Série Zoologia, Porto Alegre*, **16**(1): 67–151.
- MENEZES, N.A. (1976): On the Cynopotaminae, a new subfamily of Characid (Osteichthyes, Ostariophysi, Characoidei). – *Arquivos de Zoologia S. Paulo*, **28**(2): 1–91.
- MILES, C. (1971): Los peces del río Magdalena. – U. T., Edic. (Reimpresión), Ibagué, Colombia, 214 pp.
- MIRANDE, J.M (2009): Weighted parsimony phylogeny of the family Characidae (Teleostei: Characiformes). – *Cladistics*, **25**: 1–39
- MONSCH, K.A. (1998): Miocene fish faunas from the northwestern Amazonia basin (Colombia, Peru, Brazil) with evidence of marine incursions. – *Palaeogeography, Palaeoclimatology, Palaeoecology*, **143**: 31–50.
- MONTOYA-BURGOS, J.I. (2003): Historical biogeography of catfish genus *Hypostomus* (Siluriformes: Loricariidae), with implications on the diversification of Neotropical ichthyofauna. – *Molecular Ecology*, **12**: 1855–1867.
- MORRONE, J.J. (2005): Cladistic biogeography: Identity and place. – *Journal of Biogeography*, **32**: 1281–1286.
- MORRONE, J.J. & CRISCI, J.V. (1995): Historical biogeography: Introduction to methods. – *Annual Review of Ecology and Systematics*, **26**: 373–401.
- MURRAY, A.M. (2004): Osteology and morphology of the characiform fish *Alestes stuhlmannii* PFEFFER, 1896 (Alestidae) from the Rufiji River basin, east Africa. – *Journal of Fish Biology*, **65**: 1412–1430.
- MURRAY, A.M. & STEWART, K.M. (2002): Phylogenetic relationships of the African genera *Alestes* and *Brycinus* (Teleostei, Characiformes, Alestidae). – *Canadian Journal of Zoology*, **88**(11): 1887–1899.
- NELSON, G. & PLATNICK, N.I. (1980): A vicariance approach to historical biogeography. – *BioScience*, **30**(5): 339–343.
- NIXON, K.C. (2002): WinClada vers. 1.00.08. Ithaca, New York. Available from <http://www.cladistics.com/> (accessed 7 December 2006).

- PANTOJA-AGREDA, F. & PANTOJA-AGREDA, C. (2003): Hábitos alimentarios de *Grundulus* sp (Pisces: Characidae) en el Lago Guamuez, Departamento de Nariño, Colombia. – *Dahlia* (Revista de la Asociación Colombiana de Ictiólogos), **6**: 113–115.
- REIS, R.E.; KULLANDER, S.O. & FERRARIS, JR., C.J. (Eds.) (2003): Check list of the freshwater fishes of South and Central America. – Edipucrs, Porto Alegre, 742 pp.
- RIBEIRO, A.C.; BENINE, R.C. & FIGUEIREDO, C.A. (2004): A new species of *Creagrutus* GÜNTHER (Teleostei: Ostariophysi: Characiformes), from the upper Rio Paraná basin, central Brazil. – *Journal of Fish Biology*, **64**: 597–611.
- ROMÁN-VALENCIA, C.; PAEPKE, H.–J. & PANTOJA, F. (2003): Una especie nueva de *Grundulus* (Teleostei: Ostariophysi: Characidae) para Colombia y redescipción de *Grundulus bogotensis* (HUMBOLDT & VALENCIENNES, 1833). – *Memoria de la Fundación La Salle de Ciencias Naturales*, **155**: 51–72.
- ROMÁN-VALENCIA, C.; RUIZ-C, R.I. & BARRIGA, R. (2005): Una nueva especie ecuatoriana del género de peces andinos *Grundulus* (Characiformes: Characidae). – *Revista de Biología Tropical*, **53**(3–4): 537–544.
- RUIZ-C., R.I. & ROMÁN-VALENCIA, C. (2006): Osteología de *Astyanax aurocaudatus* EIGENMANN, 1913 (Pisces, Characidae), con notas sobre la validez de *Carlastyanax GÉRY*, 1972. – *Animal Biodiversity and Conservation*, **29**(1): 49–64.
- SERRA, J.P. & LANGEANI, F. (2006): Redescipção e osteologia de *Bryconamericus exodon* EIGENMANN, 1907 (Ostariophysi, Characiformes, Characidae). – *Biota Neotropica*, **6**(3): 1–14.
- SIDLAUSKAS, L.B. & VARI, R.P. (2008): Phylogenetic relationships within the South American fish family Anostomidae (Teleostei, Ostariophysi, Characiformes). – *Zoological Journal of the Linnean Society*, **154**: 70–210.
- TAYLOR, W.R. & VAN DYKE, G.C. (1985): Revised procedures for staining and clearing small fishes and other vertebrates for bone and cartilage. – *Cybiurn*, **9**(2): 107–119.
- VAN DER HAMMEN, T. (1992): Historia, ecología y vegetación. – Corporación Colombia para la Amazonia, Aracua, Bogotá, 411 pp.
- VAN DER HAMMEN, T. (2000): Aspectos de historia y ecología de la biodiversidad norandina y amazónica. – *Revista de la Academia Colombiana de Ciencias Exactas, Físicas y Naturales*, **24**(91): 231–245.
- VAN VELLER, M.G.P.; ZANDEE, M. & KORNET, D.J. (1999): Two requirements for obtaining valid common patterns under different assumptions in vicariance biogeography. – *Cladistics*, **15**: 393–406.
- VAN VELLER, M.G.P.; KORNET, D.J. & ZANDEE, M. (2000): Methods in vicariance biogeography: Assessment of implementations of assumptions 0, 1, and 2. – *Cladistics*, **16**: 319–345.
- VARI, R.P. & HAROLD, A.S. (2001): Phylogenetic study of the neotropical fish genera *Creagrutus* GÜNTHER and *Piabina* Reinhardt (Teleostei: Ostariophysi: Characiformes), with a revision of the Cis-Andean species. – *Smithsonian Contributions to Zoology*, **613**: 1–239.
- WEITZMAN, S.H. (1962): The osteology of *Brycon meeki*, a generalized characid fish, with an osteological definition of the family. – *Stanford Ichthyological Bulletin*, **8**(1): 1–77.
- WEITZMAN, S.H. (1964): Osteology and relationships of South American characid fishes of subfamilies Lebiasininae and Erythrininae with special reference to subtribe Nannostomina. – *Proceedings of the United States National Museum*, **116**(3499): 127–169.
- WEITZMAN, S.H. & FINK, W.L. (1983): Relationships of the neon tetras, a group of south american freshwater fishes (Teleostei, Characidae), with comments on the phylogeny of new world. – *Bulletin of Museum of Comparative Zoology*, **150**(6): 339–395.
- WEITZMAN, S.H. & FINK, W.L. (1971): A new species of characid fish of the genus *Nematobrycon* from the Rio Calima of Colombia (Pisces, Characoidei, Characidae). – *Beaufortia*, **248**(19): 57–77.
- WEITZMAN, S.H. & FINK, S.V. (1985): Xenobryconin phylogeny and putative pheromone pumps in Grandulocaudine fishes (Teleostei: Characidae). – *Smithsonian Contributions to Zoology*, **421**: 1–121.
- WEITZMAN, S.H. & MALABARBA, L.R. (1999): Systematics of *Spintherobolus* (Teleostei: Characidae: Cheirodontinae) from eastern Brazil. – *Ichthyological Exploration of Freshwaters*, **10**: 1–43.
- WEITZMAN, S.H.; MENEZES, N.A., EVERS, H.G. & BURNS, J.R. (2005): Putative relationships among inseminating and externally fertilizing characids, with a description of a new genus and species of Brazilian inseminating fish bearing an anal-fin gland in males (Characiformes: Characidae). – *Neotropical Ichthyology*, **3**(3): 329–360.
- WINTERBOTTOM, R. (1980): Systematics, osteology and phylogenetic relationships of fishes of the Ostariophysan subfamily Anostominae. – *Life Sciences Contribution Royal Ontario Museum*, **123**: 1–112.
- ZANATA, A.M. & AKAMA, A. (2004): *Myxiops aphos*, new characid genus and species (Characiformes: Characidae) from the rio Lençóis, Bahia, Brazil. – *Neotropical Ichthyology*, **2**(2): 45–54.
- ZANATA, A.M. & VARI, R.P. (2005): The family Alestidae (Ostariophysi, Characiformes): a phylogenetic analysis of a trans-Atlantic clade. – *Zoological Journal of the Linnean Society*, **145**: 1–144.